



DAON

MOTORS

The Power to Surprise

Kia is the newest and most exciting force of change in the automotive world and we are ready to change the way you feel and think about driving. More than just a promise, we are committed to making driving a true pleasure for customers across the globe. With youthful and dynamic styling and the latest in advanced technologies, Kia cars are turning heads the world over with the power to surprise. From the Picanto to the Telluride, Kia offers a full lineup of sedans, SUVs and MPVs that are not only practical and stylish but downright exhilarating to drive. Keep your eyes on Kia because our best has yet to come.

About Kia Motors Corporation

Kia Motors (www.kia.com) is a maker of world-class quality vehicles for the young-at-heart. Founded in 1944, Kia today sells around 3 million vehicles a year in over 190 countries, with 52,000 employees worldwide, annual revenues of over KRW 58 trillion (about US\$50 billion) and manufacturing facilities in six countries. Kia is spearheading the transition to electric vehicles and pursuing mobility services to help tackle urban challenges around the world. The company's brand slogan – "The Power to Surprise" – represents Kia's global commitment to surprise the world with exciting, inspiring experiences that go beyond expectations.

For more information, please visit the Kia Motors Global Media Center at www.kianewscenter.com.



<https://www.facebook.com/Kiamotorsworldwide>



https://twitter.com/Kia_Motors



<https://www.instagram.com/kiamotorsworldwide/>



<https://www.youtube.com/user/KiaBUZZ>



Kia Motors Corporation
www.kia.com

2003-MS-GE-LHD



The Power to Surprise



All-new
SORENTO

A WHOLE NEW LEVEL

Building on a solid legacy of all-weather practicality, the new Kia Sorento arrives with an all-new platform designed for superior safety and performance. Roomier and more inviting, it's also an SUV that's easy to get comfortable with. And when it comes to driving, it's the most fun Sorento ever.



THE BOLD NEW LOOK OF PRACTICALITY



The aesthetic details of the new Sorento are firmly grounded in functionality. You can see it in the aerodynamic wheel spokes, the position-establishing geometric LED lamps, and the air intakes that cool brake and engine components. From any side, these practical improvements result in strikingly bold design.



LED rear combination lamps



19-inch alloy wheels



LED projection headlights



AN SUV ENGINEERED TO PLEASE DRIVERS

New, responsive engines and transmissions make driving a pure joy. Nimble steering and an agile suspension help keep you in control, while ensuring that the ride remains smooth. With a clear performance edge, the Sorento is never boring, and it's always ready to pull its weight.

AN INTRIGUINGLY ALLURING PROFILE

The Sorento exudes a sense of excitement and anticipation. Its sleek lines seem poised for action, and seven people can ride in comfort while being protected by advanced handling dynamics and forward-thinking safety features. Occupants will also enjoy Sorento's truly empowering connectivity. Now more than ever, practicality is a good look.





▣ The new Sorento cuts through the air with a drag coefficient of 0.32, the lowest of all Kia SUVs. The secret is in the details, like the rear-spoiler garnish, sub-frame panels, and wheel designs. They add up to a quieter, more stable ride, and lower fuel consumption.





STYLISH LINES WITH STAYING POWER

■ The wraparound form of the Sorento cockpit draws you in with its sculpted surfaces and smooth lines. Large touchscreens and steering-wheel controls require minimal eye contact and are easy to tap and move through. Sturdy inner-door panels are designed to keep looking great year in and year out.

■



With elegant seating for six or seven, the Sorento interior offers a high standard of practical luxury, including heated and ventilated front seats, and headrests, cupholders, and USB terminals in all three rows. Automatic dual-zone climate control helps everyone stay comfortable.





FOR AN UNCOMPROMISING ROAD TRIP

▣ Dream getaways are now a reality. The Sorento can take you and your companions along with all your gear to some truly amazing places thanks to comfortable seating for up to seven, a roof rack, a choice of engines with the power to tow a small trailer, and the support of DRIVE WISE advanced driver assistance systems.

▣

**SEAMLESS DELIVERY
OF THE INFORMATION YOU NEED**

Being a driver is not what it used to be. Modern technology means that there is now an infinite supply of information out there, so prioritization is everything. The Sorento surrounds you with a simple presentation of only crucial data, while keeping distractions to an absolute minimum. Its simplicity will grow on you from the very start.



Bluetooth multi-connection

Stay connected with your devices. Two paired Bluetooth® phones can be connected at the same time for streaming music. Only one phone can be used for hands-free calls.

10.25-inch touchscreen

The pinchable, zoomable, high-resolution display presents data for navigation and audio, as well as the rear view monitor and parking guidance. The customizable screen can be split into two views at once, and voice controls are now integrated.



Head-up display

The head-up display projects an image equivalent to an 8.5-inch screen onto the windshield, enabling you to monitor speed, remaining distance to empty, cruise control, and DRIVE WISE system data without having to take your eyes away from the road.



Smartphone wireless charger

Now with up to 15W of electric power, the charging pad in the front center console bin lets you charge compatible mobile phones wirelessly. The display shows orange while charging and turns green when charging is complete.



12.3-inch TFT LCD supervision cluster

The supervision cluster intelligently presents speed, warnings, and navigation cues. The views adapt in real time, showing blind spot video images of the indicated target lane.





Ample luggage space

Behind the third-row seats is 57 liters of cargo space, enough for two suitcases or golf bags. Fold the third row flat to increase cargo space to 245 liters.

Smart power tailgate

Simply stand behind the vehicle for three seconds while holding the smart key, and the tailgate will open automatically. You can even set the opening height to fit your preferences.



SPACE FOR BIG ADVENTURES AND EVERYDAY ESCAPES

The Sorento is about possibilities and practicality. It provides the perfect space for relaxation as well as amazing flexibility in case you need to make room for an unusually large purchase, help a friend move, or disappear into the countryside for a long weekend.

Premium Sound System / Driver Talk and Quiet Mode

The audio system's in-car Driver Talk intercom lets the driver speak with back-seat passengers without having to shout or turn around. Quiet Mode switches the audio system from full-interior sound to a reduced-volume, front-seat only mode.

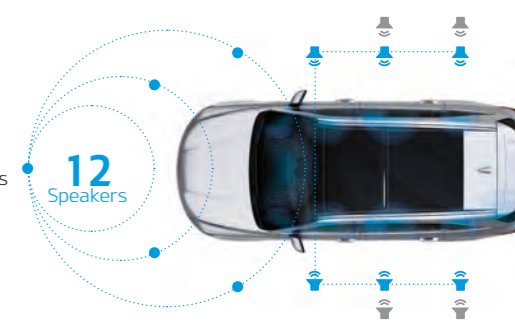

Easy entry and exit

Second-row seats slide and fold to offer walk-in accommodation for third-row occupants. Lift the walk-in handle to slide the seat forward, and press the walk-in button to fold the seatback forward.

Seven seats for maximum flexibility

The Sorento is available with comfortable seating for five or seven. The second row can be configured into two separate foldable seats with armrests, or a 60:40 split-folding row of three seats. The third row includes two separately foldable seats. Fold some or all seatbacks to expand the cargo space.

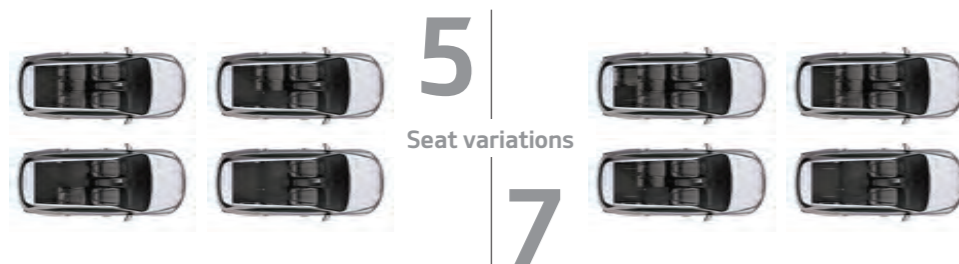



Forward Collision-Avoidance Assist (FCA)

FCA uses a front view camera and front radar to detect vehicles, pedestrians or cyclists ahead. By warning and braking automatically, it can help you avoid or reduce the severity of an accident.

Lane Keeping Assist (LKA)

There's no need to worry about drifting out of your lane. LKA monitors your position in the lane, and if you begin to wander to either side, it alerts you and even steers you back into place to keep you precisely where you need to be.

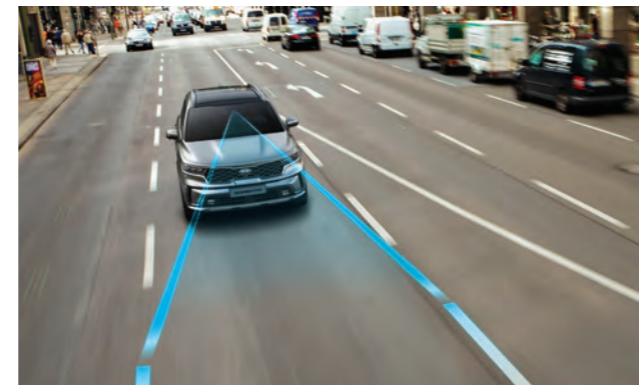

AN EXTRA SET OF EYES TO KEEP YOU PROTECTED AT ALL TIMES

Tapping into the power of the latest sensing technology and intelligent processing, the Sorento helps you stay aware of your position and the movement of the vehicles, bicycles and pedestrians around you. It can even step in to help prevent collisions and keep pedestrians safe.



SAFETY | EFFICIENCY | CONVENIENCE

DRIVE WISE is Kia's sub-brand encompassing the latest Advanced Driver Assistance System (ADAS) technologies that ensure the ultimate in occupant and pedestrian safety, while never sacrificing the pleasure of driving. DRIVE WISE helps to eliminate the tediousness and fatigue from even the most stressful daily commutes.



Blind-Spot View Monitor (BVM)

Activate the turn signal and BVM will present live video footage on the instrument cluster of other vehicles in the blind spot on the side of the intended lane change.



Smart Cruise Control (SCC)

With a simple touch of a button, SCC will maintain the driver's selected speed. Using the front view camera and front radar, the system allows the vehicle to automatically maintain a safe following distance, reduce speed, and even come to a complete stop and start again, if necessary.



Surround View Monitor (SVM)

When maneuvering in confined spaces, multiple cameras give you a zoomable, 360° overhead view around the vehicle, so you can steer and park with confidence.



THE RIGHT BALANCE OF POWER AND FINESSE

Easy to maneuver and fun to drive, the new, lighter-weight Sorento is available with a choice of spirited and efficient engines, while the transmissions give you precise control over shift points. Terrain settings optimize the vehicle systems for specific road surfaces.

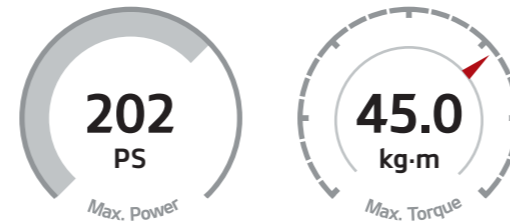

Smartstream D2.2 diesel engine

This quiet, efficient, low-vibration diesel powerplant yields 202 ps at 3,800 rpm with maximum torque output of 45.0kg-m across a wide 1,750-2,750 rpm range.



Gasoline 3.5 MPI	
Max.Power	272 ps / 6,400 rpm
Max.Torque	33.8 kg-m / 5,000 rpm
Mated transmission	8AT
Gasoline 2.5 MPI	
Max.Power	180 ps / 6,000 rpm
Max.Torque	23.7 kg-m / 4,000 rpm
Mated transmission	6AT



Drive mode

Switch between 'Drive' and 'Terrain' modes with the simple push of a button. Turn the knob to select the mode that suits you best: COMFORT for everyday driving, ECO for optimal fuel efficiency, SPORT for quicker acceleration, or SMART which employs a learning algorithm that automatically adjusts gear shift intervals based on recent driving patterns.

Multi-Terrain Control

On challenging surfaces, SNOW, MUD and SAND modes ensure optimal tire traction over different road conditions. A quick glance at the center cluster or AVN will confirm Terrain mode status.

SNOW mode

Simply select the Multi-Terrain Control's SNOW mode and the advanced AWD system employs variable power delivery to the rear wheels to optimize tire traction on slippery snow-covered roads.

MUD mode

Enjoy maximum traction even on muddy roads thanks to a new coupling unit that provides electronically controlled torque distribution among the four wheels. Upon sensing individual wheel slip, the smart controller automatically compensates by increasing torque to the wheels with greater traction.

SAND mode

The smart controller automatically adjusts the power distribution ratio between the front and rear axles and will automatically allocate the correct amount of torque and/or braking power to individual wheels to ensure the highest level of safety on sand-covered surfaces.

8-speed DCT (with dial gear selector)

Dual-clutch design translates into quicker gear changes and improved fuel efficiency, all at the simple turn of a dial. With eight speeds, optimal engine RPMs can be maintained at more vehicle speed levels for superior acceleration and economy.



8-speed DCT

Count on smooth shifts with the 8-speed Dual Clutch Transmission. Its algorithms make gear changes quick and seamless, and help to maximize fuel efficiency. Choose your own shift points with the sporty paddle shift levers.



Electronic Parking Brake (EPB)

The Electronic Parking Brake can be applied and released by a switch in the center console.



Paddle shift levers

Access more torque sooner and choose your own shift points for the 8- or 6-speed automatic transmission instantly, without taking your hands from the steering wheel. The levers are mounted right at your fingertips.



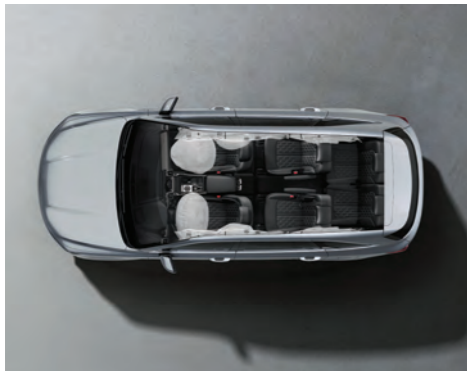

6-airbag system

To help protect occupants and potentially reduce injuries in the event of a collision, seven airbags are offered: driver, front passenger, two front-side, and two side-curtain.



Vehicle Stability Management (VSM)

Continuously monitoring road conditions, VSM helps to protect occupants by automatically controlling the steering and brakes when the road gets bumpy.



Hill-start Assist Control (HAC)

HAC prevents the vehicle from rolling backward when at a standstill on an incline by gently applying the brakes for up to two seconds while you move your foot from the brake pedal to the accelerator.



Electronic Stability Control (ESC)

Electronic Stability Control (ESC) automatically applies braking to help you stay on course when it detects potential skidding.

OCCUPANT SAFETY IS OUR FIRST AND FOREMOST PRIORITY

Sudden bumps in the road. An icy patch. Tricky curves ahead. The Sorento is designed to respond to these situations before you're even aware of them, and helps you stay in control. It also helps protect you from the sudden and complex mix of forces that materialize during an impact.

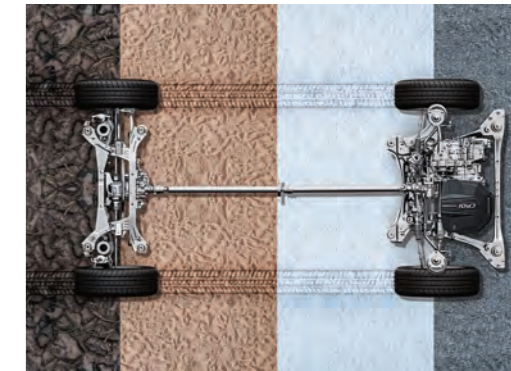

Multi Terrain Control ensures that AWD, engine, transmission, and electronic stability control technologies can be coordinated to ensure grip and stability on a range of surfaces.

Phenomenal torsional rigidity and hot-stamped steel

Lighter steel body members are engineered for substantial torsional rigidity, or resistance to twisting forces, so bumps in the road are absorbed with precision, while impact forces during a collision are managed in ways that better protect cabin occupants. Hot-stamping adds strength to steel in critical spots.

Triple-ring structure

The multi-ring body structure, including B- and C-pillars, hatch opening, roof, and crossmembers, gives Sorento superior body rigidity.

Stronger front structure

A new crossmember and side members at the front of the engine compartment, coupled with reinforcements at the front of the cabin, offer better protection.

Reinforced door openings

Integrated hot stamping of the steel around the doors give the Sorento cabin a new level of protection.

Fortified tailgate opening

Reinforcements around the rear hatch help protect occupants and keep the rear liftgate functional in the event of a collision.

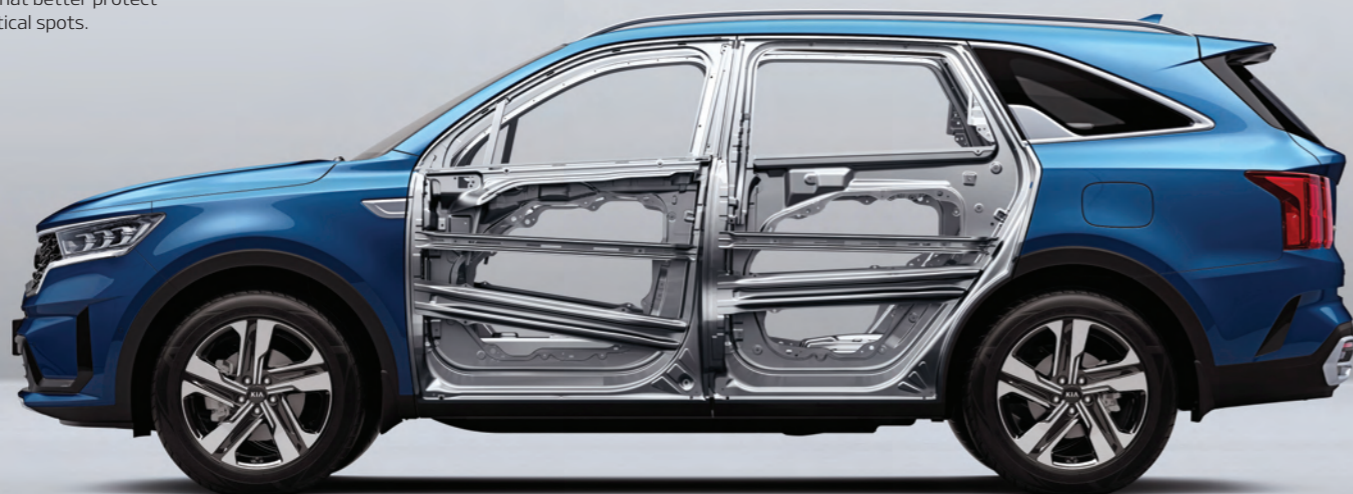

Advanced AWD Coupling

The electronic control AWD coupling system continuously monitors driving conditions and the driver's intentions, while distributing torque accordingly to the front and rear axles. The system is optimally controlled with Terrain Mode (Sand/Mud/Snow) and Drive Mode (Comfort/Eco/Sport) settings. The system also adds stability during cornering, helps eliminate unintended over- and understeer by reducing unwanted traction forces at the front and rear axles, and helps reduce fuel consumption and emissions.

Rack-type motor-driven power steering (R-MDPS)

A firm, solid feel and unprecedented steering response are simultaneously achieved with optional R-MDPS.

Reinforced front subframe

The front subframe is reinforced and optimized with a new box-shaped geometry for durability, ride, and impact load management.

Sloped front strut bearing

Suspension friction has now been reduced at every angle of steering input by applying a rearward slope to the front strut bearing.



PERSONALIZATION AND AMENITIES



A. Panorama sunroof / B. Dual-zone full auto air conditioning system and 3rd row rear air conditioning system / C. Air-ventilated front seats & seat warmers
D. 2nd row console airvent / E. 3rd row rear air conditioning system / F. 8-inch display / G. Steering wheel remote controls / H. Integrated memory system (IMS)
I. 1st row seat back USB charger

J. Driver's seat adjuster / K. Rear side-window sunshades / L. Bose™ premium sound system / M. Passenger walk-in device / N. Electro-chromic mirror (ECM)
O. Stainless steel pedals / P. Electric 2nd row walk-in switch / Q. Hidden rear wiper / R. Seatback double pocket / S. 2nd row seat side pocket
T. Rear door armrest cup holder / U. 3rd row armrest cup holder

INTERIOR TRIM CHOICES

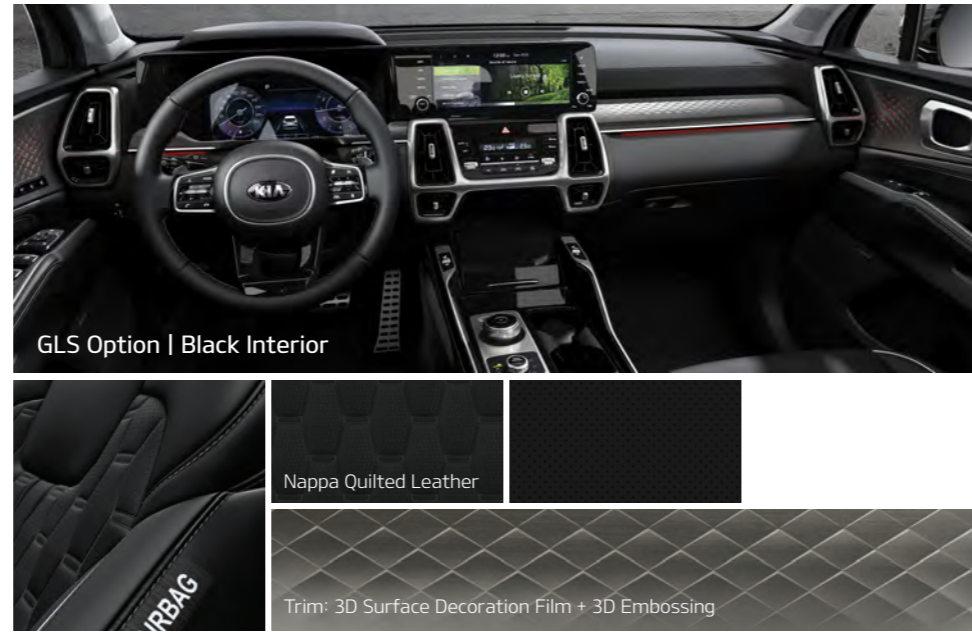
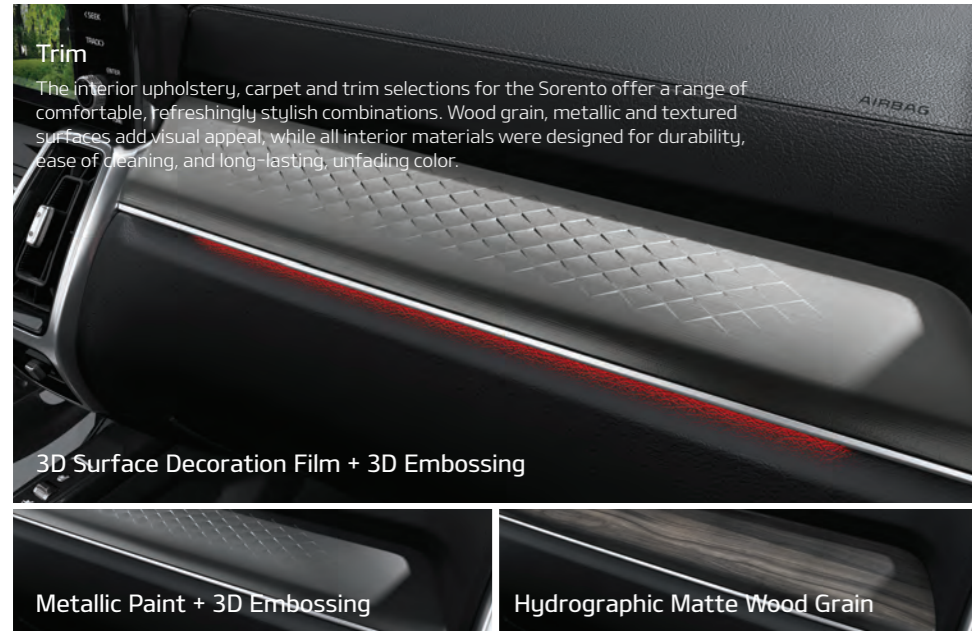

Even more choices



A. Radiator grill (Glossy black paint)



B. Radiator grill (Black paint)



C. LED projection headlights



D. LED headlights



E. Rear combination lamps (LED type)



F. Rear combination lamps (Bulb type)



G. Outside mirror & repeater

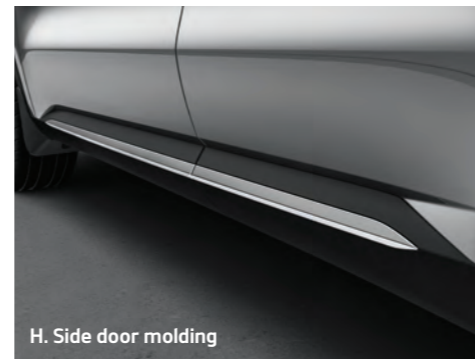

H. Side door molding

Exterior Colors

Clear White (UD)

Snow White Pearl (SWP)

Silky Silver (4SS)

Steel Gray (KLG)

Aurora Black Pearl (ABP)

Platinum Graphite (ABT)

Essence Brown (BE2)

Gravity Blue (B4U)

Runway Red (CR5)

Mineral Blue (M4B)

Wheels



17-inch | 235/65R17 alloy wheel



18-inch | 235/60R18 alloy wheel



18-inch | 235/60R18 alloy wheel



19-inch | 235/55R19 alloy wheel

Dimensions (mm)

※ Based on 19-inch wheels

Overall length	4,810
Overall width	1,900
Overall height	1,700 (with roof rack)
Wheelbase	2,815
Wheel tread (front/rear)	1,646/1,656*
Overhang (front/rear)	930/1,065
Leg room (1 st /2 nd /3 rd)	1,052/1,060/752
Head room (1 st /2 nd /3 rd)	1,024/994/935
Shoulder room (1 st /2 nd /3 rd)	1,500/1,475/1,345
Minimum ground clearance	176

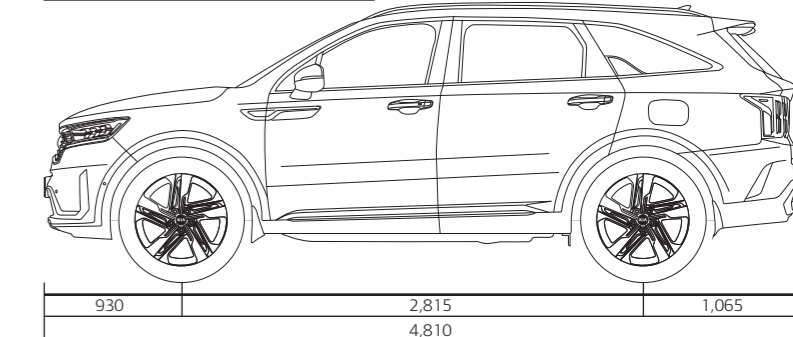
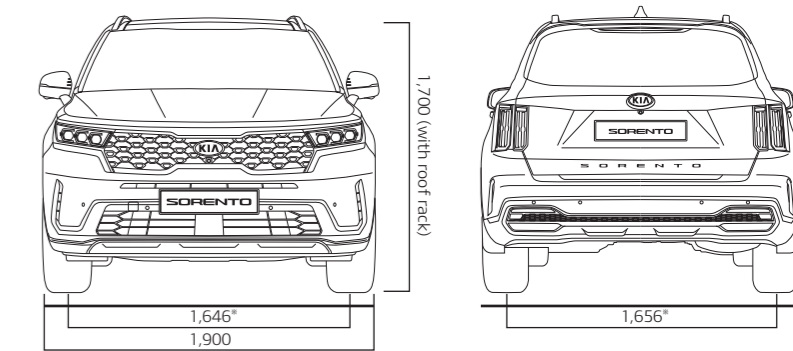

※ All information contained herein was based upon the latest available information at the time of printing. Descriptions are believed to be correct, and Kia Motors Corporation makes every effort to ensure accuracy, however accuracy cannot be guaranteed. From time to time, Kia Motors Corporation may need to update or make changes to the vehicle features and other vehicle information reported in this brochure. Some vehicles shown include optional equipment that may not be available in some regions. All video and camera screens shown are simulated. Kia Motors Corporation, by the publication and dissemination of this material, does not create any warranties, either express or implied, to any Kia products. Contact your local Kia dealer for the most current information.

KEEPING YOUR PRIORITIES IN THE RIGHT PLACE



Making it safely to your destination. Exploring new places. Spending quality time with family and friends. All are excellent reasons to choose the Kia Sorento. So get in, buckle up, and prepare for the best kind of surprises.

